



BDX63 – A – B – C

NPN SILICON DARLINGTON POWER TRANSISTOR

The BDX63, BDX63A, BDX63B and BDX63C are mounted in TO-3 metal package. High current power darlington transistors designed for power amplification and switching applications. The complementary PNP are BDX62, BDX62A, BDX62B, BDX62C. Compliance to RoHS.

ABSOLUTE MAXIMUM RATINGS

Symbol	Ratings		Value	Unit	
V_{CEO}	Collector-Emitter Voltage		BDX63	60	V
			BDX63A	80	
			BDX63B	100	
			BDX63C	120	
V_{CEV}	Collector-Emitter Voltage	$V_{BE} = -1.5\text{ V}$	BDX63	80	V
			BDX63A	100	
			BDX63B	120	
			BDX63C	140	
V_{EBO}	Emitter-Base Voltage		5.0	V	
I_C	Collector Current		$I_{C(RMS)}$	8	A
			I_{CM}	12	
I_B	Base Current		0.15	A	
P_T	Power Dissipation	@ $T_C = 25^\circ$	90	W	
T_J	Junction Temperature		-55 to +200	$^\circ\text{C}$	
T_S	Storage Temperature				

THERMAL CHARACTERISTICS

Symbol	Ratings	Value	Unit	
R_{thJ-C}	Thermal Resistance, Junction to Case		1.94	$^\circ\text{C/W}$

BDX63 – A – B – C

ELECTRICAL CHARACTERISTICS

TC=25°C unless otherwise noted

Symbol	Ratings	Test Condition(s)		Min	Typ	Max	Unit
$V_{CE(SUS)}$	Collector-Emitter Breakdown Voltage (*)	$I_C=0.1\text{ A}$ $I_B=0$ $L=25\text{mH}$	BDX63	60	-	-	V
			BDX63A	80	-	-	
			BDX63B	100	-	-	
			BDX63C	120	-	-	
I_{CEO}	Collector Cutoff Current	$V_{CE}=30\text{ V}$ $V_{CE}=40\text{ V}$ $V_{CE}=50\text{ V}$ $V_{CE}=60\text{ V}$	BDX63	-	-	0.5	mA
			BDX63A	-	-		
			BDX63B	-	-		
			BDX63C	-	-		
I_{EBO}	Emitter Cutoff Current	$V_{BE}=5\text{ V}$	BDX63	-	-	5.0	mA
			BDX63A				
			BDX63B				
			BDX63C				
I_{CBO}	Collector-Base Cutoff Current	$V_{CBO}=60\text{ V}$ $V_{CBO}=400\text{ V}$ $T_{CASE}=200^\circ\text{C}$ $V_{CBO}=80\text{ V}$ $V_{CBO}=50\text{ V}$ $T_{CASE}=200^\circ\text{C}$ $V_{CBO}=100\text{ V}$ $V_{CBO}=60\text{ V}$ $T_{CASE}=200^\circ\text{C}$ $V_{CBO}=120\text{ V}$ $V_{CBO}=70\text{ V}$ $T_{CASE}=200^\circ$	BDX63	-	-	0.2	-
			BDX63	-	-	2	
			BDX63A	-	-	0.2	
			BDX63A	-	-	2	
			BDX63B	-	-	0.2	
			BDX63B	-	-	2	
			BDX63C	-	-	0.2	
			BDX63C	-	-	2	
$V_{CE(SAT)}$	Collector-Emitter saturation Voltage (*)	$I_C=3.0\text{ A}$ $I_B=12\text{ mA}$	BDX63	-	-	2	V
			BDX63A				
			BDX63B				
			BDX63C				
V_F	Forward Voltage (pulse method)	$I_F=3\text{ A}$	BDX63	-	1.2	-	V
			BDX63A				
			BDX63B				
			BDX63C				
V_{BE}	Base-Emitter Voltage (*)	$I_C=3.0\text{ A}$ $V_{CE}=3\text{ V}$	BDX63	-	-	2.5	V
			BDX63A				
			BDX63B				
			BDX63C				

BDX63 – A – B – C

ELECTRICAL CHARACTERISTICS

TC=25°C unless otherwise noted

Symbol	Ratings	Test Condition(s)	Min	Typ	Max	Unit		
F_{hfe}	Cut-off frequency	$V_{CE}=3\text{ V}$ $I_C=3\text{ A}$	BDX63	-	100	-	kHz	
			BDX63A					
			BDX63B					
			BDX63C					
f_T	Transition Frequency	$V_{CE}=3\text{ V}, I_C=3\text{ A}$ $f=1\text{ MHz}$	BDX63	-	7	-	MHz	
			BDX63A					
			BDX63B					
			BDX63C					
h_{FE}	D.C. current gain (*)	$V_{CE}=3\text{ V}$ $I_C=0.5\text{ A}$	BDX63	-	2500	-	-	
			BDX63A					
			BDX63B					
			BDX63C					
		$V_{CE}=3\text{ V}$ $I_C=3\text{ A}$	BDX63	1000	-	-		-
			BDX63A					
			BDX63B					
			BDX63C					
		$V_{CE}=3\text{ V}$ $I_C=8\text{ A}$	BDX63	-	2600	-		-
			BDX63A					
			BDX63B					
			BDX63C					

(*) Pulse Width $\approx 300\ \mu\text{s}$, Duty Cycle $\angle 2.0\%$

BDX63 – A – B – C

MECHANICAL DATA CASE TO-3

DIMENSIONS (mm)		
	min	max
A	11	13.10
B	0.97	1.15
C	1.5	1.65
D	8.32	8.92
F	19	20
G	10.70	11.1
N	16.50	17.20
P	25	26
R	4	4.09
U	38.50	39.30
V	30	30.30

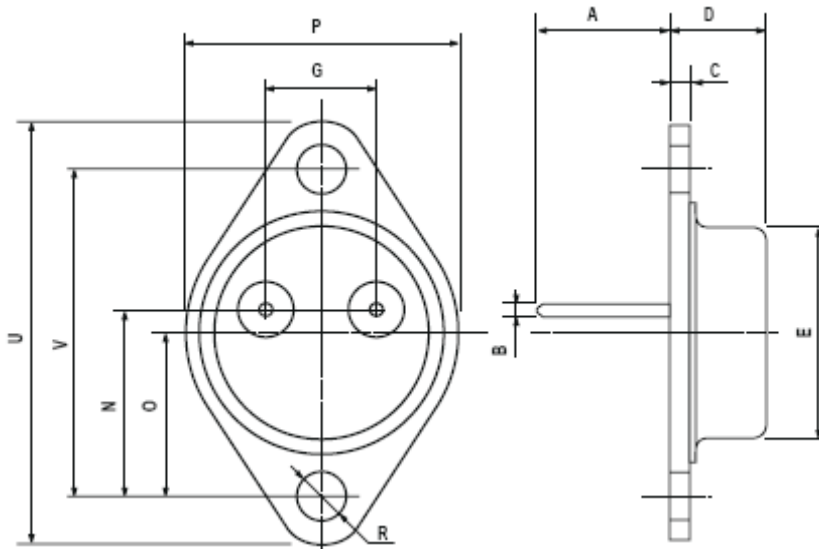

Pin 1 :	Base
Pin 2 :	Emitter
Case :	Collector

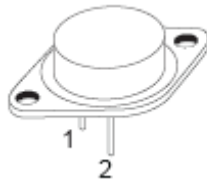

Revised September 2012

Information furnished is believed to be accurate and reliable. However, Comset Semiconductors assumes no responsibility for the consequences of use of such information nor for any infringement of patents or other rights of third parties which may result from its use. Data are subject to change without notice. Comset Semiconductors makes no warranty, representation or guarantee regarding the suitability of its products for any particular purpose, nor does Comset Semiconductors assume any liability arising out of the application or use of any product and specifically disclaims any and all liability, including without limitation consequential or incidental damages. Comset Semiconductors' products are not authorized for use as critical components in life support devices or systems.