

PNP 2N2905 – 2N2905A

SILICON PLANAR EPITAXIAL TRANSISTOR

The 2N2905 and 2N2905A are PNP transistors mounted in TO-39 metal case . They are intended for high speed switching and general purpose applications. Compliance to RoHS

ABSOLUTE MAXIMUM RATINGS

Symbol	Ratings		Value	Unit
V_{CEO}	Collector-Emitter Voltage	2N2905A	-60	V
		2N2905	-40	
V_{CBO}	Collector-Base Voltage	2N2905A	-60	V
		2N2905	-60	
V_{EBO}	Emitter-Base Voltage	2N2905A	-5	V
		2N2905	-5	
I_C	Collector Current	2N2905A	-600	mA
		2N2905		
P_D	Total Power Dissipation	@ $T_{amb} = 25^\circ$	0.6	Watts
		2N2905A		
P_D	Total Power Dissipation	@ $T_{case} = 25^\circ$	3	
		2N2905A		
T_J	Junction Temperature	2N2905A	200	$^\circ C$
		2N2905		
T_{Stg}	Storage Temperature range	2N2905A	-65 to +200	$^\circ C$
		2N2905		

THERMAL CHARACTERISTICS

Symbol	Ratings		Value	Unit
R_{thJ-a}	Thermal Resistance, Junction to ambient in free air	2N2905A	58.3	$^\circ C/W$
		2N2905		
R_{thJ-c}	Thermal Resistance, Junction to case	2N2905A	292	$^\circ C/W$
		2N2905		

PNP 2N2905 – 2N2905A

ELECTRICAL CHARACTERISTICS

TC=25°C unless otherwise noted

Symbol	Ratings	Test Condition(s)	Min	Typ	Max	Unit	
I_{CBO}	Collector Cutoff Current	$V_{CB}=-50\text{ V}$ $I_E=0$	2N2905A	-	-	-10	nA
			2N2905	-	-	-20	
		$V_{CB}=-50\text{ V}$, $I_E=0$ $T_J=150^\circ\text{C}$	2N2905A	-	-	-10	μA
			2N2905	-	-	-20	
I_{CEX}	Collector Cutoff Current	$V_{CE}=-30\text{ V}$ $V_{BE}=0.5\text{ V}$	2N2905A 2N2905	-	-	-50	nA
V_{CEO}	Collector Emitter Breakdown Voltage	$I_C=-10\text{ mA}$ $I_B=0$	2N2905A 2N2905	-60 -40	-	-	V
V_{CBO}	Collector Base Breakdown Voltage	$I_C=-10\text{ }\mu\text{A}$ $I_E=0$	2N2905A 2N2905	-60	-	-	V
V_{EBO}	Emitter Base Breakdown Voltage	$I_E=-10\text{ }\mu\text{A}$ $I_C=0$	2N2905A 2N2905	-5	-	-	V
h_{FE}	DC Current Gain (*)	$I_C=-0.1\text{ mA}$ $V_{CE}=-10\text{ V}$	2N2905A 2N2905	75 35	-	-	-
		$I_C=-1\text{ mA}$ $V_{CE}=-10\text{ V}$	2N2905A 2N2905	100 50	-	-	
		$I_C=-10\text{ mA}$ $V_{CE}=-10\text{ V}$	2N2905A 2N2905	100 75	-	-	
		$I_C=-150\text{ mA}$ $V_{CE}=-10\text{ V}$	2N2905A 2N2905	100 40	-	300 120	
		$I_C=-500\text{ mA}$ $V_{CE}=-10\text{ V}$	2N2905A 2N2905	50 30	-	-	
$V_{CE(SAT)}$	Collector-Emitter saturation Voltage (*)	$I_C=-150\text{ mA}$ $I_B=-15\text{ mA}$	2N2905A 2N2905	-	-	-0.4	V
		$I_C=-500\text{ mA}$ $I_B=-50\text{ mA}$	2N2905A 2N2905	-	-	-1.6	
		$I_C=-150\text{ mA}$ $I_B=-15\text{ mA}$	2N2905A 2N2905	-	-	-1.3	
		$I_C=-500\text{ mA}$ $I_B=-50\text{ mA}$	2N2905A 2N2905	-	-	-2.6	
$V_{BE(SAT)}$	Base-Emitter saturation Voltage (*)	$I_C=-150\text{ mA}$ $I_B=-15\text{ mA}$	2N2905A 2N2905	-	-	-1.3	V
		$I_C=-500\text{ mA}$ $I_B=-50\text{ mA}$	2N2905A 2N2905	-	-	-2.6	
f_T	Transition frequency	$I_C=-50\text{ mA}$ $V_{CE}=-20\text{ V}$ $f=100\text{ MHz}$	2N2905A 2N2905	200	-	-	MHz
t_d	Delay time	$I_C=-150\text{ mA}$, $I_B=-15\text{ mA}$		-	-	10	ns
t_r	Rise time	$-V_{CC}=-30\text{ V}$		-	-	40	
C_{CBO}	Collector-Base capacitance	$I_E=I_C=0$, $V_{CB}=-10\text{ V}$ $f=100\text{ kHz}$	2N2905A 2N2905	-	-	8	μF
C_{EBO}	Emitter-Base capacitance	$I_C=I_E=0$, $V_{EB}=-2\text{ V}$ $f=100\text{ kHz}$	2N2905A 2N2905	-	-	30	μF

(*) Pulse conditions : $t_p < 300\text{ }\mu\text{s}$, $\delta = 2\%$

PNP 2N2905 – 2N2905A

MECHANICAL DATA CASE TO-39

DIMENSIONS (mm)		
	min	max
A	8.50	9.39
B	7.74	8.50
C	6.09	6.60
D	0.40	0.53
E	-	0.88
F	2.41	2.66
G	4.82	5.33
H	0.71	0.86
J	0.73	1.02
K	12.70	-
L	42°	48°

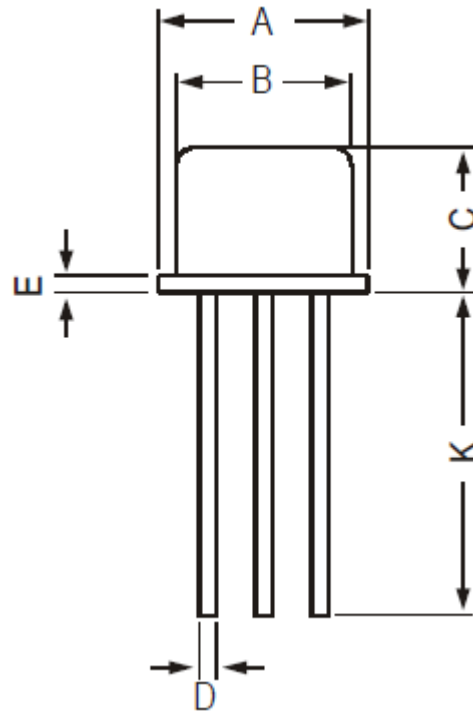

Pin 1 :	Emitter
Pin 2 :	Base
Pin 3 :	Collector
Case :	Collector

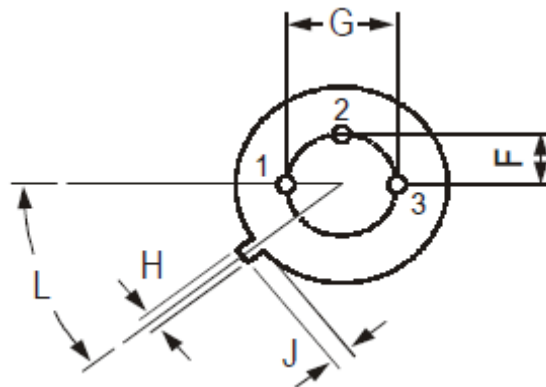

Revised August 2012

Information furnished is believed to be accurate and reliable. However, Comset Semiconductors assumes no responsibility for the consequences of use of such information nor for any infringement of patents or other rights of third parties which may result from its use. Data are subject to change without notice. Comset Semiconductors makes no warranty, representation or guarantee regarding the suitability of its products for any particular purpose, nor does Comset Semiconductors assume any liability arising out of the application or use of any product and specifically disclaims any and all liability, including without limitation consequential or incidental damages. Comset Semiconductors' products are not authorized for use as critical components in life support devices or systems.